

# SUPERPRESSURE

## AIR OPERATED DIAPHRAGM-TYPE COMPRESSORS

|                   |                     |                          |
|-------------------|---------------------|--------------------------|
| <b>46-14021-2</b> | <b>TWO STAGE</b>    | <b>10K &amp; 30K PSI</b> |
| <b>46-14023</b>   | <b>TWO STAGE</b>    | <b>6K &amp; 10K PSI</b>  |
| <b>46-14025-2</b> | <b>SINGLE ENDED</b> | <b>10K PSI</b>           |
| <b>46-14035-2</b> | <b>DOUBLE ENDED</b> | <b>10K PSI</b>           |
| <b>46-14060-2</b> | <b>SINGLE ENDED</b> | <b>30K PSI</b>           |
| <b>46-14065</b>   | <b>SINGLE ENDED</b> | <b>6K PSI</b>            |
| <b>46-14067</b>   | <b>DOUBLE ENDED</b> | <b>6K PSI</b>            |
| <b>46-14068</b>   | <b>TWO STAGE</b>    | <b>6K &amp; 30K PSI</b>  |

**This Manual is for:**

**Compressor Part No.** : \_\_\_\_\_  
**Sales Order No.** : \_\_\_\_\_  
**Serial No.** : \_\_\_\_\_  
**Date Manufactured** : \_\_\_\_\_

NEWPORT SCIENTIFIC, INC  
8246-E SANDY COURT  
JESSUP, MD 20794  
PHONE: 301-498-6700 FAX: 301-490-2313  
WEBSITE: [www.newport-scientific.com](http://www.newport-scientific.com)  
E-MAIL: [sales@newport-scientific.com](mailto:sales@newport-scientific.com) or [technical@newport-scientific.com](mailto:technical@newport-scientific.com)

## CONTENTS

- I. INSPECTION
- II. INTRODUCTION
- III. PRINCIPLES OF OPERATION
- IV. CHARACTERISTICS
  - a. Gas/Liquid Service Conversion
  - b. Ordering Data Check Valves
- V. INSTALLATION & OPERATION
  - a. Installation
  - b. Operation
  - c. Priming Procedure
  - d. Verify Check Valve Operation
- VI. TROUBLESHOOTING
- VII. MAINTENANCE
  - a. Stroke Adjustment Procedures
    - 1. Single Head Compressors
    - 2. Double Head Compressors
  - b. Diaphragm Replacement
  - c. Gas Check Valve Replacement
  - d. Pressure Limiting Device Adjustment
- VIII. RECOMMENDED SPARE PARTS & ½" PISTON ASSEMBLY # 85001000300
- IX. ASSEMBLY DRAWINGS & CAPACITY CURVES – SEE LIST
- X. SPECIFICATIONS

## **I. INSPECTION**

If damage is discovered upon unpacking the equipment, an immediate request should be forwarded to the delivering carrier to perform an inspection and prepare a concealed-damage report. Concurrently, the nature and extent of damage should be reported to Newport Scientific, Inc., giving catalog and serial numbers, so that action may be initiated to replace damaged parts, or instructions issued for the return of the apparatus.

## **II. INTRODUCTION**

The Superpressure Diaphragm-Type Gas Compressors handle fluids of all types with absolute purity. The fluid being compressed comes into contact only with clean, dry, corrosion-resistant metallic surfaces. The compressors are suited for all types of laboratory applications as well as for pilot plant and industrial applications requiring low gas flows. The compressors operate at a 14 to 1 maximum compression ratio and are designed to circulate or boost gas from a low pressure to pressures of 6,000, 10,000, or 30,000 psi. These compressors may be used for testing and calibration of critical devices such as missile system components, etc., where hydrostatic pressure testing and calibration would be difficult or impossible.

These compressors may be easily cleaned. Fluids other than ordinary oil, such as oxygen-compatible fluorinated products, may be used for diaphragm pulsing if required for specific applications. Compressors can be constructed of materials other than those normally supplied for particular corrosion-resistant applications on special order. The compressors when specifically cleaned and serviced, are also used for oxygen service.

These compressors are adaptable to either gas or intermittent liquid service. Changeover from one to the other is accomplished by interchanging a set of intake and exhaust check valves. Single or double ball check valves are available from Newport Scientific, Inc. which enable the compressors to be used for intermittent liquid service.

## **III. PRINCIPLES OF OPERATION**

The plunger of the compression head is reciprocated as in a pump. Oil from the storage bulb is compressed by the plunger, which in turn pulses the diaphragm. The fluid to be compressed is taken in and discharged on the opposite side of the diaphragm through the check valves in the head plate on the down and up stroke of the diaphragm. Oil is drawn into the chamber beneath the diaphragm by the suction created on the plunger backstroke. Excess oil in the chamber can flow back to the storage bulb during the forward plunger stroke through the pressure limiting device. This built-in hydraulic device is manually adjustable and ensures that the discharge pressure of the compressor cannot exceed a preset limit. The plunger stroke is preset so that under normal operating conditions, oil will not flow through the pressure limiting device unless the maximum discharge pressure is exceeded.

#### IV. CHARACTERISTICS

- Contamination-free gas compression.
- Parts in contact with gas are made of the following materials:
- Upper head plates, 17-4PH SS; Valves, 302, 304, 316, 17-4PH SS and Nylon 101; Diaphragms, 302 SS.
- Compressor is suitable for suction at constant or continually varying suction pressures up to the maximum permissible discharge pressure.
- Compression ratios of up to 14-to-1 are obtainable for each stage.
- Diaphragm life in excess of 500 hours of operation normally attained.
- Absence of stuffing box permits leak-free operation.
- Elastomer packing provides a leak-free oil seal, long life and never needs tightening.
- Interchangeable check valves permit either continuous gas or intermittent liquid service.
- Check valves can be easily removed for cleaning and replacement.
- Floating hydraulic plunger ensures minimum wear on packing.

#### GAS/LIQUID SERVICE CONVERSION

These compressors can be adapted for intermittent liquid service. To convert from gas to intermittent liquid service or vice-versa, replace the set of intake and exhaust check valves on the compressors with the set specified in Table for the particular service application. On the 6,000 and 10,000 psi gas head, for intermittent service with normal liquids, double-ball check valves must be used. Difficult liquids are water, volatile hydrocarbons, low or high-viscosity liquids and liquids containing sediments. On 30,000 psi gas heads, for intermittent liquid service, double-ball check valves must be used for all liquids.

#### PRECAUTION

**\*\*Liquid service check valves CANNOT be used on Two-Stage Compressors.\*\***

#### ORDERING DATA AND SPECIFICATIONS FOR CHECK VALVES

| COMPRESSOR CATALOG NUMBER          | QTY  | STANDARD GAS CHECK VALVES INLET/DISCHARGE    | LIQUID SERVICE SINGLE BALL INLET/DISCHARGE | LIQUID SERVICE DOUBLE BALL INLET/DISCHARGE |
|------------------------------------|------|--|--|--|
| 46-14025-2<br>46-14065             | 1 Ea | 44-11102<br>44-11107                         | 44-14100<br>44-14115                       | 44-14210<br>44-14215                       |
| 46-14035-2<br>46-14023<br>46-14067 | 2 Ea | 44-11102<br>44-11107                         | 44-14100<br>44-14115                       | 44-14210<br>44-14215                       |
| 46-14060-2                         | 1 Ea | 44-13100<br>44-13120                         |  | 44-13140<br>44-13160                       |
| 46-14021-2<br>46-14068             | 1 Ea | 44-11102<br>44-11107<br>44-13100<br>44-13120 |  |  |

\*Also used where ultra-pure cleaning is required.

Each check valve listed in Table has a ¼ inch O.D. female tubing opening. Special-Inlet Adapter 45-16705 for liquid service can be used with the 44-13140, 44-14100, and 44-14210 Intake Check Valves when a ¼ inch NPT connection is desired. This adapter converts the ¼ inch O.D. female connection to ¼ inch NPT, female.

## V. INSTALLATION & OPERATION

### CAUTION

For oxygen service, use HALOCARBON or similar oils to prevent reaction with the oxygen. Thoroughly clean vital areas for oxygen service. The use of a HALOCARBON grease on bolt threads and other hardware is suggested. Recommendations for special applications may be obtained from the SUPERPRESSURE Engineering Dept.

### INSTALLATION

1. Remove plug from oil reservoir, remove plugs from inlet and discharge gas check-valves and from air-supply connections.

### NOTE

Unit may be bench operated without tie-down bolts. Mounting holes are provided where their use is necessary. Mounting data may be obtained from the detailed drawings.

2. An air-filter pressure-regulator-lubricator (Cat. No. 46-13753) is included as part of the compressor. A dry air source with pressure not to exceed 125 psi is connected to the air filter.
3. Air-exhaust ports exhaust through mufflers to the atmosphere. Where desirable, the exhaust may be vented away from the unit. We recommend a minimum vent-pipe of ¾-inch to preclude malfunction of air-cycling valve because of backpressure.
4. Fill lubricator to correct level with lubricating oil (SAE 20)\* Oil feed rate is factory-set at 2-drops /minute at maximum operating pressure. This oil provides the only lubrication necessary for the air operator.
5. Install a 5- to 10- micron, dry-type filter (Cat. No. 49-14405) in the gas-inlet line between the gas supply and the compressor.
6. Connect gas-suction line (use SUPERPRESSURE Tubing, Cat. No. 45-11020) to port on head marked "IN" on units 46-14021-2, 46-14025-2, 46-14060-2, 46-14023 46-14068 and 46-14065. Connect the gas-suction line to inlet manifold on unit 46-14035-2 and 46-14067.

## **OPERATION**

### **NOTE**

Before turning on the air pressure, turn out (unscrew) the pressure regulator adjustment screw. The unit can be started at the air-shutoff valve (not supplied) in the air-supply line, or by screwing in the adjustment on the pressure regulator. The latter operation is not normally intended for start-stop control, but is used to regulate the maximum pressure to the compressor.

\*Newport Scientific, Inc. uses Oildyne Hydraulic Fluid 15-40.

### **PRECAUTION**

If dirt enters the compressor, the diaphragm and check valves may be damaged. It is absolutely essential that the incoming gas is filtered. We suggest a 5 or 10 micron in-line Filter such as Cat. # 49-14405.

Also any lines to be placed between the Filter and the compressor should be thoroughly cleaned. Flush with solvent using a syringe, and blow dry with clean air or gas. (Even a new piece of high pressure tubing may contain sufficient particulate matter to foul the check valves).

To operate the motor-driven compressor, turn on electric power to the compressor. Observe the gas discharge pressure to ensure that the compressor is operating properly. If the compressor fails to build-up pressure, shut off power and perform the "Priming Procedure" in the next paragraph.

### **PRIMING PROCEDURE**

To prime the compressor, perform the following:

1. Close off the gas discharge line.
2. Apply suction pressure to the compressor inlet. (The term suction pressure means the positive pressure applied to the compressor inlet, e.g. a minimum suction pressure of 700 psi is recommended for 10,000 psi discharge on 46-13411-2).
3. Add oil to the reservoir if required.
4. Loosen the stop nut on the top of pressure limiting device, being careful not to lose the setting. Reverse the set screw back until it no longer applies tension to the spring. The stop nut will turn with the set screw, thereby maintaining the original Factory setting.
5. Run the compressor. While it is running, loosen the large gland nut at the base of the pressure limiting device by 1-1/2 turns, and pull back on the body of the limiter to release the orifice piece. This removes all force from the seat and allows fresh oil to be pulled in from the reservoir.

The large gland nut should be loosened just for a couple of strokes of the compressor and then retightened. Some oil will be spilled out during the above operation.

6. Return the setscrew to its' original setting and retighten the stop nut.

#### **PROCEDURE FOR VERIFYING PROPER CHECK VALVE OPERATION**

1. Install pressure gauges on Compressor Inlet & Outlet, if not already present.
2. Apply suction pressure of 1,000 psi to Compressor Inlet.
3. Operate Compressor.
4. If either gauge fluctuates wildly then remove check valves and clean or replace.

## VI. TROUBLESHOOTING

| TROUBLE                                  | PROBABLE CAUSE  | CORRECTIVE ACTION   |
|--|---|---|
| Air Drive Inoperative                    | <ol style="list-style-type: none"> <li>1. Low air pressure, or clogged air line filters</li> <li>2. Improper lubrication</li> <li>3. Loose or broken connection</li> <li>4. Malfunction of pilot valves or air-transfer valve</li> <li>5. Improper stroke adjustment</li> </ol> | <ol style="list-style-type: none"> <li>1. Check air pressure. Clean air line or filter, install proper size air line or filter, install proper size air line (3/8" pipe min).</li> <li>2. Check lubricator adjustment. Set to 2 drops min., running free.</li> <li>3. Tighten or replace.</li> <li>4. Replace pilot valve, air-transfer valve or both.</li> <li>5. Refer to Stroke Adjustment.</li> </ol>                             |
| Pump stalls before pressure develops     | <ol style="list-style-type: none"> <li>1. Insufficient air pressure</li> <li>2. Air line restriction</li> <li>3. Improper cylinder lubricator</li> <li>4. Pressure limiting device locked in</li> </ol>   | <ol style="list-style-type: none"> <li>1. Obtain proper air pressure.</li> <li>2. Remove restriction.</li> <li>3. Check lubricator and grade of oil used. Set to 2 drops min. Running free.</li> <li>4. Back-off pressure limiting device screw.</li> </ol>   |
| Pump operative developing less than max. | <ol style="list-style-type: none"> <li>1. Inlet pressure too low</li> <li>2. System leakage</li> <li>3. Air pressure too low</li> <li>4. Faulty inlet &amp; discharge check valve</li> </ol>  | <ol style="list-style-type: none"> <li>1. Keep compression ratio at 14:1.</li> <li>2. Isolate pump and check for leaks.</li> <li>3. Obtain proper air pressure.</li> <li>4. Check gauges in inlet and discharge line with pump cylinder under normal conditions. If inlet gauge fluctuates radically, replace inlet check valve assembly. If discharge gauge fluctuates radically, replace discharge check valve assembly.</li> </ol> |



| TROUBLE   | PROBABLE CAUSE  | CORRECTIVE ACTION   |
|---|---|---|
| Pump operative developing less than max. pressure         | 5.Pump not primed.<br>6.Defective hydraulic check valve or pressure limiting device<br>7.Improper stroke adjustment   | 5.Refer to priming procedure.<br>6.Replace faulty valve or device. Observe oil reservoir for check valve action.<br>7.Refer to Stroke Adjustment.   |
| Pump developing maximum pressure, output volume incorrect | 1.External leaks on check valve and diaphragm (check by bubble testing)<br>2.Oil pressure limiter set too low. Oil level in oil reservoir will move up & down with each stroke.<br>3.Malfuction in inlet and discharge check valves.<br>4.Low input pressure<br>5.Ruptured diaphragm(s)<br>6.Improper stroke adjustment | 1.Tighten or replace as necessary.<br>2.Increase by turning IN adjustment screw to 6,600 psi, 11,000 psi, or 32,000 psi, depending on type of compressor. <u>DO NOT</u> adjust this device unless necessary.<br>3.See above.<br>4.Check for proper compensation ratio.<br>5.Replace with new diaphragm(s).<br>6.Refer to Stroke Adjustment. |

## VII. MAINTENANCE

### STROKE ADJUSTMENT PROCEDURES

Pivot-valve assembly is located on threaded supports and a plate. The plate has elongated holes to allow the pivot valves to slide either toward or away from the cam for fine-stroke adjustments. The stroke setting at the pivot-valve assembly is made at the factory and should not normally require changing; however, if it becomes necessary to change or reset, proceed as follows:

#### SINGLE-HEAD COMPRESSORS

1. Position the ball valve so that the space between the bottom face of the mounting plate and the upper face of the spacer is approximately 1-1/16". Lock in place. (See Compressor Assembly Drawing)
2. Loosen the two hex-head screws holding the ball valves to the mounting plate. Slide both ball valves inward toward the plunger. Tighten both screws to hold valves in place.
3. Start compressor with no gas pressure. Operate very slowly.
4. Block the exhaust port of the upper ball valve with a finger and let the plunger go to the very bottom of the bore. Keep finger in place.

5. With inside calipers measuring the distance between the face of the body (not the packing nut) and the face of the coupling.
6. Remove finger from the ball valve exhaust. The plunger will return. Let the compressor continue to run slowly.
7. Increase the calipers measurement  $1/16$ "; i.e., if the measurement was  $5/16$ ", increase to  $3/8$ ".
8. Loosen screws slightly on ball valves. Insert calipers between body face and coupling.
9. Slide both ball valves out until the coupling touches the calipers while compressor is running. This must be done in very small increments.
10. Tighten the screws on the ball valves and again measure stroke.
11. Allow compressor to run for several minutes and observe the oil reservoir bowl. If it appears that the oil level is rising and falling with each stroke, or if the pressure limiting device is set for too low a pressure, refer to paragraph setting pressure limiting device.
12. To shorten the stroke, break the screws and very tightly tap the ball valves in. Tighten screws.
13. Repeat steps 11 and 12, above, until the oil level remains steady.

#### **CAUTION**

**The pressure limiting device should never heat during operation.**

#### **DOUBLE-HEAD COMPRESSORS**

1. Position the ball valve so that the space between the bottom face of the mounting plate and the upper face of the spacer is approximately  $1-1/16$ ". Lock in place. (See Compressor Assembly Drawing).
2. Break the two hex-head screws holding the ball valves to the mounting plate. Slide both ball valves in toward the plunger. Tighten both screws to hold valves in place.  
  
Perform steps 1 and 2 on both ends before starting compressor.
4. Start the compressor with no gas pressure.
5. Block the exhaust port of the upper ball valve with a finger and let the plunger go to the very bottom of the bore.
6. Using inside calipers, measure the distance between the face of the body (not the packing nut) and the face of the coupling.

7. Remove finger from the ball valve exhaust. The plunger will return. Let the compressor continue to run slowly.
8. Open the calipers 1/16"; i.e., if the measurement was 5/16", increase to 3/8".
9. Loosen screws slightly on ball valves. Insert calipers between body face and coupling.
10. Slide both ball valves out until the coupling touches the calipers while compressor is running. This must be done in very small increments.
11. Tighten the screws on the ball valves and measure the stroke again.
12. Repeat steps 2 through 8 for the other ball valve.
13. Repeat steps 11, 12, and 13 above.

### **REPLACING DIAPHRAGM**

1. Shut down unit, closing off gas inlet and discharge lines.
2. Crack connections to gas check valves to allow trapped pressure to escape.
3. Remove all gas connections.
4. Secure hydraulic section in some form of clamping device.
5. Remove head bolts, remove head, and inspect. Inspect valves, clean and cover with clean cloth.
6. Remove diaphragm.

#### **NOTE**

The 6,000 and 10,000 psi units have one diaphragm per head; the 30,000 psi units have two diaphragms per head.

7. Remove preservative from new diaphragm(s) thoroughly clean and put new diaphragm(s) in place.
8. Install head connections by reversing removal procedures. (Use check valve as guide for proper relocation).

#### **NOTE**

Lubricate washer and bolt threads with bearing grease for normal operation; use HALOCARBON grease for oxygen services.

9. Hand tighten all head bolts. Then sequentially tighten opposing bolts with torque wrench in equal increments of 10 ft-lbs until final tightness. (Torque to approximately 150 ft-lbs for 6,000 and 10,000 psi Head and 350 ft-lbs for 30,000 psi Head)
10. Attach all gas connections.
11. Prime the compressor as described in Priming Instructions.

#### **GAS CHECK VALVE REPLACEMENT**

1. Shut down unit as previously described.
2. Remove gas connections as previously described.
3. Remove check valves and examine for wear or damage.
4. Replace seat assembly in check valves if required.
5. If check valves are of the single ball or double ball type, it is recommended that they be completely replaced if found defective.

#### **ADJUSTMENT OF PRESSURE LIMITING DEVICE**

##### **NOTE**

The Pressure Limiting Device was preset by Newport Scientific and should never need re-adjustment. This device was set to release oil back to the storage bulb when the discharge pressure reached 110% of the maximum pressure rating of the compressor. This setting was obtained by turning the set screw at the top of the pressure limiter until the desired release pressure was obtained.

The set screw was then held stationary while the outer stop nut was tightened down to the limiter body to lock in the setting. As long as the stop nut is not turned relative to the set screw, the set screw can be turned out and in for priming and still maintain the original factory setting.

If the stop nut has been turned relative to the set screw, the following procedure can be followed to reproduce the original setting.

1. Install pressure gauges in the inlet & outlet lines of the compressor if not already present.
2. Make sure the system is primed by performing the **Priming Procedure**.
3. Make sure check valves are operating properly according to the **Procedure for Verifying Proper Check Valve Operation**.
4. Stop compressor operation.

5. Loosen outer stop nut on top of pressure limiter and turn set crew back until all tension is removed from the spring.
6. Apply suction pressure of at least 1000 psi.
7. Adjust set screw slowly inward to obtain the following maximum discharge pressure -
  - for 6,000 psi compressors, set to 6,600 psi
  - for 10,000 psi compressors, set to 11,000 psi
  - for 30,000 psi compressors, set to 33,000 psi

**NOTE**

For a two stage compressor, set up to 5,000 psi on first stage.

**NOTE**

Outlet pressure gauge needle will fluctuate slightly with each piston stroke, use the highest reading on each stroke when setting the pressure.

8. Hold set screw stationary and tighten outer stop nut to lock in pressure setting.

**NOTE**

It is not recommended that the pressure limiter be set at a pressure lower than the original factory setting.

## VIII. RECOMMENDED SPARE PARTS

| DESCRIPTION               | CAT. NO<br>OR<br>PART NO. | 46-<br>14025-2 | 46-<br>14060-2 | 46-<br>14035-2 | 46-<br>14021-2 | 46-<br>14023 | 46-<br>14068 | 46-<br>14065 | 46-<br>14067 |
|---------------------------|---------------------------|----------------|----------------|----------------|----------------|--------------|--------------|--------------|--------------|
| CHECK VALVE,<br>HYDRAULIC | 44-14110                  | 1              | 1              | 2              | 2              | 2            | 2            | 1            | 2            |
| CHECK VALVE,<br>INTAKE    | 44-11102                  | 1              |                | 2              | 1              | 2            | 1            | 1            | 2            |
| CHECK VALVE,<br>DISCHARGE | 44-11107                  | 1              |                | 2              | 1              | 2            | 1            | 1            | 2            |
| CHECK VALVE,<br>INTAKE    | 44-13100                  |                | 1              |                | 1              |              | 1            |              |              |
| CHECK VALVE,<br>DISCHARGE | 44-13120                  |                | 1              |                | 1              |              | 1            |              |              |
| DIAPHRAGM                 | 62018000500               | 1              | 2              | 2              | 3              | 1            | 2            |              |              |
| DIAPHRAGM                 | 84001001100               |                |                |                |                | 1            | 1            | 1            | 2            |
| OILER                     | P1004002900               | 1              | 1              | 2              | 2              | 2            | 2            | 1            | 2            |
| SOFTGOOD<br>PACKING KIT   | 85001000900               | 1              |                | 2              | 1              | 1            |              |              |              |
| SOFTGOOD<br>PACKING KIT   | 85001000500               |                | 1              |                | 1              |              | 1            |              |              |
| SOFTGOOD<br>PACKING KIT   | 85001001100               |                |                |                |                | 1            | 1            | 1            | 2            |
| PACKING<br>RETAINER       | 64042002500               | 1              |                | 2              | 1              | 1            | 1            |              |              |
| PACKING<br>RETAINER       | 65013002700               |                | 1              |                | 1              |              |              |              |              |
| PACKING<br>RETAINER       | 84001000800               |                |                |                |                | 1            | 1            | 1            | 2            |
| PACKING<br>FOLLOWER       | 64042002200               | 1              |                | 2              | 1              | 1            | 1            |              |              |
| PACKING<br>FOLLOWER       | 65013002800               |                | 1              |                | 1              |              |              |              |              |
| PACKING<br>FOLLOWER       | 84001000700               |                |                |                |                | 1            | 1            | 1            | 2            |

PART NO. 85001000300 – ½” PISTON ASSEMBLY (CHEVRON PACKINGS TO POLYPACK)  
Please Call Newport Scientific, Inc. for further information on this part.

## **IX. ASSEMBLY DRAWINGS**

### **COMPRESSOR # 46-14021-2 AIR OPERATED TWO STAGE 10 & 30K PSI**

|                    |                                      |
|--------------------|--------------------------------------|
| 46-14021-2         | Compressor Assembly Sheet 1 & 2      |
| 62037002802        | Head Assembly 10,000 PSI             |
| 63034001802        | Head Assembly 30,000 PSI             |
| 44-11102           | Intake Check Valve 10,000 PSI        |
| 44-11107           | Discharge Check Valve 10,000 PSI     |
| 44-13100           | Intake Check Valve 30,000 PSI        |
| 44-13120           | Discharge Check Valve 30,000 PSI     |
| 44-14110           | Inlet Check Valve Single Ball        |
| 62006001200        | Assembly Relief Valve-Liquid Service |
| 77053000900        | Air Drive Double End                 |
| Curve 10 & 30K Air | Capacity Curve                       |

### **COMPRESSOR # 46-14023 AIR OPERATED TWO STAGE 6 & 10K PSI**

|                   |                                      |
|-------------------|--------------------------------------|
| 46-14023          | Compressor Assembly Sheet 1 & 2      |
| 62037002902       | Head Assembly 10,000 PSI             |
| 84001001500       | Head Assembly 6,000 PSI              |
| 44-11102          | Intake Check Valve 10,000 PSI        |
| 44-11107          | Discharge Check Valve 10,000 PSI     |
| 44-14110          | Inlet Check Valve Single Ball        |
| 62006001200       | Assembly Relief Valve-Liquid Service |
| 77053000900       | Air Drive Double End                 |
| Curve 6 & 10K Air | Capacity Curve                       |

### **COMPRESSOR # 46-14025-2 AIR OPERATED SINGLE ENDED 10K PSI**

|                     |                                      |
|---------------------|--------------------------------------|
| 46-14025-2          | Compressor Assembly Sheet 1 & 2      |
| 62028003002         | Head & Body Assembly 10,000 PSI      |
| 44-11102            | Intake Check Valve 10,000 PSI        |
| 44-11107            | Discharge Check Valve 10,000 PSI     |
| 44-14110            | Inlet Check Valve Single Ball        |
| 62006001200         | Assembly Relief Valve-Liquid Service |
| 77053001000         | Air Drive Single End                 |
| Curve 10K SE DE Air | Capacity Curve                       |

**COMPRESSOR # 46-14035-2 AIR OPERATED DOUBLE ENDED 10K PSI**

|                     |                                      |
|---------------------|--------------------------------------|
| 46-14035-2          | Compressor Assembly Sheet 1 & 2      |
| 62037002802         | Head Assembly Left Side 10,000 PSI   |
| 62037002902         | Head Assembly Right Side 10,000 PSI  |
| 44-11102            | Intake Check Valve 10,000 PSI        |
| 44-11107            | Discharge Check Valve 10,000 PSI     |
| 44-14110            | Inlet Check Valve Single Ball        |
| 62006001200         | Assembly Relief Valve-Liquid Service |
| 77053000900         | Air Drive Double End                 |
| Curve 10K SE DE Air | Capacity Curve                       |

**COMPRESSOR # 46-14060-2 AIR OPERATED SINGLE ENDED 30K PSI**

|                  |                                      |
|------------------|--------------------------------------|
| 46-14060-2       | Compressor Assembly Sheet 1 & 2      |
| 63035000902      | Head Assembly 30,000 PSI             |
| 44-13100         | Intake Check Valve 30,000 PSI        |
| 44-13120         | Discharge Check Valve 30,000 PSI     |
| 44-14110         | Inlet Check Valve Single Ball        |
| 62006001200      | Assembly Relief Valve-Liquid Service |
| 77053001000      | Air Drive Single End                 |
| Curve 30K SE Air | Capacity Curve                       |

**COMPRESSOR # 46-14065 AIR OPERATED SINGLE END 6K PSI**

|                   |                                      |
|-------------------|--------------------------------------|
| 46-14065          | Compressor Assembly Sheet 1 & 2      |
| 85005000100       | Head Assembly 6,000 PSI              |
| 44-11102          | Intake Check Valve 10,000 PSI        |
| 44-11107          | Discharge Check Valve 10,000 PSI     |
| 44-14110          | Inlet Check Valve Single Ball        |
| 62006001200       | Assembly Relief Valve-Liquid Service |
| 77053001000       | Air Drive Single End                 |
| Curve 6 & 30K Air | Capacity Curve                       |



**COMPRESSOR # 46-14067 AIR OPERATED DOUBLED END 6K PSI**

|              |                                      |
|--------------|--------------------------------------|
| 46-14067     | Compressor Assembly 1 & 2            |
| 84001001500  | Head Assembly 6,000 PSI Right Side   |
| 85005000100  | Head Assembly 6,000 PSI Left Side    |
| 44-11102     | Intake Check Valve 10,000 PSI        |
| 44-11107     | Discharge Check Valve 10,000 PSI     |
| 44-14110     | Inlet Check Valve Single Ball        |
| 62006001200  | Assembly Relief Valve-Liquid Service |
| 77053000900  | Air Drive Double End                 |
| Curve 6K Air | Capacity Curve                       |

**COMPRESSOR # 46-14068 AIR OPERATED TWO STAGE 6 & 30K PSI**

|                   |                                      |
|-------------------|--------------------------------------|
| 46-14068          | Compressor Assembly Sheet 1 & 2      |
| 84001000300       | Head Assembly 6,000 PSI              |
| 63034001802       | Head Assembly 30,000 PSI             |
| 44-11102          | Intake Check Valve 10,000 PSI        |
| 44-11107          | Discharge Check Valve 10,000 PSI     |
| 44-13100          | Intake Check Valve 30,000 PSI        |
| 44-13120          | Discharge Check Valve 30,000 PSI     |
| 44-14110          | Inlet Check Valve Single Ball        |
| 62006001200       | Assembly Relief Valve-Liquid Service |
| 77053000900       | Air Drive Double End                 |
| Curve 6 & 30K Air | Capacity Curve                       |

# X. SPECIFICATIONS

## AIR OPERATED DIAPHRAGM COMPRESSOR SPECIFICATIONS CHART

| ITEM                                      | 46-14025-2<br>(SINGLE<br>END 10K) | 46-14035-2<br>(DOUBLE<br>END 10K) | 46-14060-2<br>(SINGLE<br>END 30K) | 46-14021-2<br>(TWO<br>STAGE<br>10, 30K) | 46-14023<br>(TWO<br>STAGE<br>6,10K) | 46-14068<br>(TWO<br>STAGE<br>6,30K) | 46-14065<br>(SINGLE<br>END<br>6K) | 46-14067<br>(DOUBLE<br>END 6K) |
|---|-----------------------------------|-----------------------------------|-----------------------------------|---|-------------------------------------|-------------------------------------|-----------------------------------|--------------------------------|
| Max. Discharge Pressure                   | 10,000PSI                         | 30,000PSI                         | 30,000PSI                         | 10,000PSI                               | 10,000PSI                           | 30,000PSI                           | 6,000PSI                          | 6,000PSI                       |
| Max. Inlet Pressure                       | Up to Discharge                   | Up to Discharge                   | Up to 10,000 psi                  | Up to 6,000PSI                          | Up to 6,000PSI                      | Up to Discharge                     | Up to Discharge                   | Up to Discharge                |
| Recommended Compression Ratio             | 14 to 1                           |                                   |                                   |   |                                     |                                     |                                   |                                |
| Min. Gas Suction Pressure                 | 700                               | 2000                              | 350                               | 150                                     | 400                                 |                                     |                                   |                                |
| Number of Stages                          | 1                                 |                                   |                                   | 2                                       | 1                                   |                                     |                                   |                                |
| Max. Air-Drive Pressure                   | 125 psi                           |                                   |                                   |   |                                     |                                     |                                   |                                |
| Min. Air-Drive Pressure (for max. rating) | 80 psi                            |                                   |                                   |   |                                     |                                     |                                   |                                |
| Mounting Position                         | Vertical                          | Horizontal                        | Vertical                          | Horizontal                              | Horizontal                          | Vertical                            | Vertical                          | Horizontal                     |
| Air Consumption                           | 20 SCFM                           | 25 SCFM                           | 40 SCFM                           | 45 SCFM                                 | 25 SCFM                             | 40 SCFM                             | 40 SCFM                           | 40 SCFM                        |
| <b>DIMENSIONS</b>                         |                                   |                                   |                                   |   |                                     |                                     |                                   |                                |
| Length                                    | 12"                               | 30"                               | 12"                               | 32"                                     | 30"                                 | 32"                                 | 12"                               | 30"                            |
| Width                                     | 14"                               | 13"                               | 14"                               | 13"                                     | 13"                                 | 13"                                 | 14"                               | 13"                            |
| Height                                    | 17"                               | 16"                               | 19"                               | 16"                                     | 16"                                 | 16"                                 |                                   | 16"                            |

| ITEM   | 46-14025-2<br>(SINGLE END<br>10K)                       | 46-14035-2<br>(DOUBLE END<br>10K)  | 46-14060-2<br>(SINGLE END<br>30K)  | 46-14021-2 (TWO<br>STAGE<br>10, 30K)  | 46-14023 (TWO<br>STAGE<br>6, 10K)   | 46-14068 (TWO<br>STAGE 6,10K)   | 46-14065<br>(SINGLE<br>END 6K)                           | 46-14067<br>(DOUBLE<br>END 6K)   |
|--|---|--|--|---|---|---|--|--|
| <b>PORTS</b>                                 |   |  |  |   |   |   |  |  |
| Drive Air<br>Inlet and<br>Exhaust            | 3/8" NPT FEMALE   |  |  |   |   |   |  |  |
| Gas Inlet &<br>Discharge                     | 1/4" AMINCO   |  |  |   |   |   |  |  |
| Recommended<br>Drive-Air<br>Line Size        | 3/8" PIPE, MINIMUM                                      |  |  |   |   |   |  |  |
| Estimated<br>Weight                          | 70 lbs. net<br>100 lbs.ship                             | 130 lbs. net<br>180 lbs.ship   | 70 lbs. net<br>100 lbs.ship  | 130 lbs. net<br>180 lbs.ship  | 130 lbs. net<br>180 lbs.ship  | 130 lbs. Net<br>180 lbs.ship  | 70lbs.<br>Net<br>100lbs.<br>ship                         | 130<br>lbs.net<br>180<br>lbs.ship  |
| Mounting                                     | 4 mounting<br>holes 17/32"<br>dia. on 8-<br>inch center | 4 mounting holes 1/2-13<br>UNC-2B thread, 1/2" deep on<br>4-5/8" centers by 6-inch<br>center<br>4 mounting holes 17/32"<br>dia. on 8-inch center | 4 mounting holes 1/2-13<br>UNC-2B thread, 1/2" deep on<br>4-5/8" centers by 6-inch<br>center | 4 mounting holes 1/2-13 UNC-2B thread, 1/2" deep<br>on 4-5/8" center by 6-inch center                                 | 4 mounting holes 1/2-13 UNC-2B thread, 1/2" deep<br>on 4-5/8" center by 6-inch center                               | 4 mounting<br>holes 1/2-<br>13 UNC-2B<br>thread 1/2"<br>deep on 4<br>5/8"<br>center by<br>6" center                       | 4<br>mounting<br>holes<br>17/32"<br>dia. on<br>8" thread | 4<br>mounting<br>holes 1/2-<br>13 UNC-2B<br>thread 1/2"<br>deep on 4<br>5/8"<br>center by<br>6" center |
| Volumetric<br>Displacemet<br>per Stroke      | 0.13 cu. in.<br>2.15 cc                                 | 0.26 in <sup>3</sup> 4.30<br>cc  | 0.0785 in <sup>3</sup><br>1.25 cc  | 1 <sup>st</sup><br>stage 0.13<br>in <sup>3</sup> 2.15 cc<br>2 <sup>nd</sup><br>stage .0785<br>in <sup>3</sup> 1.25 cc | 1 <sup>st</sup><br>stage .36<br>in <sup>3</sup> 5.90 cc<br>2 <sup>nd</sup><br>stage 0.13<br>in <sup>3</sup> 2.15 cc | 1 <sup>st</sup><br>stage<br>0.36 in <sup>3</sup><br>5.90 cc<br>2 <sup>nd</sup> stage<br>0.0785 in <sup>3</sup><br>1.25 cc | 0.36 in <sup>3</sup><br>5.90 cc                          | 0.72 in <sup>3</sup><br>11.80 cc   |
| Speed (max. at<br>free flow)                 | 130 Strokes/Min.  |  |  |   |   |   |  |  |
| Stroke<br>Length (max.<br>under<br>pressure) | 1   |  |  |   |   |   |  |  |
| Exhaust Air<br>Vent (if<br>required)         | 3/4" PIPE MINIMUM, 10FT. MAXIMUM                        |  |  |   |   |   |  |  |
| Oil for Air<br>Lubricator                    | **SAE 20**  |  |  |   |   |   |  |  |
| Oil for<br>Hydraulic<br>Head                 | NORMAL, SAE 20**, HALOCARBON OIL FOR OXYGEN SERVICE     |  |  |   |   |   |  |  |

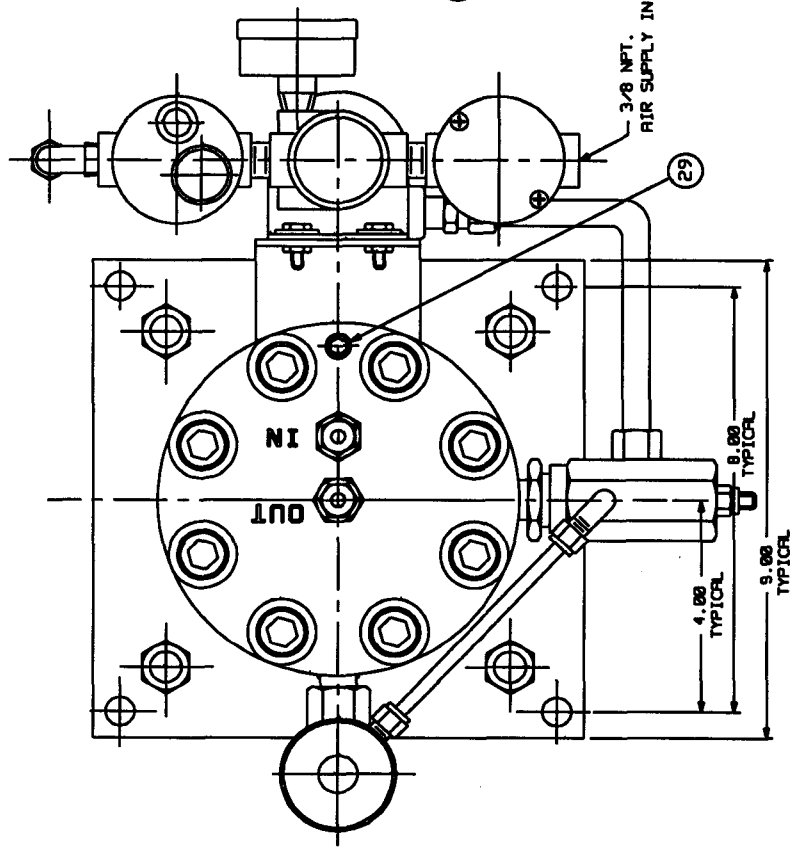
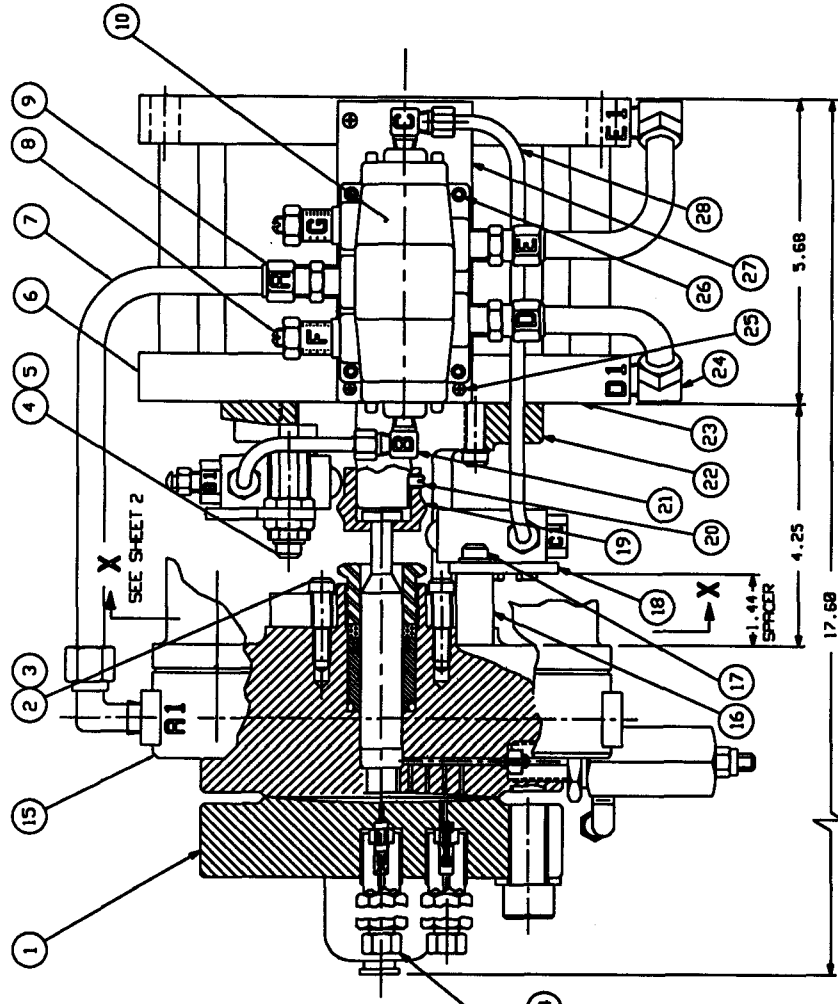

**NOTES:**

1. USE ONE (1) SET SCREW ONLY FOR END OF SHAFT NEAREST TO FLAT ON SHAFT, HOLD END PLAY OF SHAFT TO A MINIMUM
2. LOW PRESSURE PNEUMATIC HOOK-UP:
  - A - MAIN AIR SUPPLY INLET, CONNECT TO A1
  - B - LOW PRESSURE TRANSFER, CONNECT TO PILOT VALVE B1
  - C - LOW PRESSURE TRANSFER, CONNECT TO PILOT VALVE C1
  - D - AIR SUPPLY TO LEFT SIDE OF PISTON, CONNECT TO D1
  - E - AIR SUPPLY TO RIGHT SIDE OF PISTON, CONNECT TO E1
  - F - EXHAUST FROM PORT D1 THROUGH MUFFLER TO ATMOSPHERE
  - G - EXHAUST FROM PORT E1 THROUGH MUFFLER TO ATMOSPHERE
3. ADJUST LUBRICATOR FOR 2 DROPS OF OIL PER MINUTE

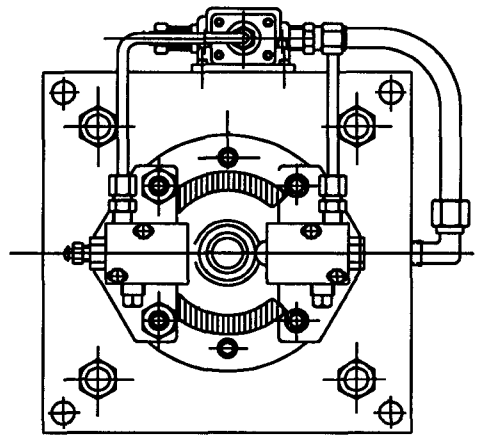

**VIEW "X-X"**

|  |  |                                |                      |
|--|--|--------------------------------|----------------------|
| <b>PROPRIETARY</b><br>This document is issued in strict confidence on condition that it is not copied, reprinted, or disclosed to a third party, wholly or in part, without the written consent of Newport Scientific Inc. |  | <b>NEWPORT SCIENTIFIC INC.</b> |                      |
| UNLESS OTHERWISE SPECIFIED DIMENSIONS ARE IN INCHES TOLERANCES:<br>FRACTIONS ±<br>DECIMALS ± XX ± .002 XXX ± .010<br>ANGLES ± 1°<br>REMOVE ALL BURRS AND SHARP EDGES<br>DO NOT SCALE THIS DRAWING                          |  | BY                             | DATE                 |
|  |  | PREPARED                       | FINISH               |
|  |  | CHECKED                        |                      |
|  |  | ENGR/ISSUED                    |                      |
|  |  | APPROVED                       |                      |
|  |  | MATERIAL                       |                      |
| TITLE<br><b>AIR OPERATED DIAPHRAM COMPRESSOR, VERTICAL, SINGLE END, 6,000 PSI, 3/4 PISTON</b>  |  | PART NO. 46-14065              |                      |
| CODE IDENT. NO.<br>59505   |  | SIZE<br>D                      | DRAWING NO. 4614065A |
| SCALE  |  | WEIGHT                         | SHEET 1 OF 2         |
| <b>SEE LIST</b>  |  |                                |                      |

| ITEM             | QTY. | DESCRIPTION                              | PART/ING. NO. | MATERIAL     |
|------------------|------|--|---------------|--------------|
| 29               | 1    | SCREW, 5/16-18UNC-2A SC. HD. CAP 5/8LG   | Q4650023520   | STEEL        |
| 28               | -    | TUBE, 1/4 O. D.                          | P1245-001     | COPPER       |
| 27               | 1    | BRACKET, VALVE MOUNTING                  | C20-77053     | STEEL        |
| 26               | 4    | SCREW, 8-32 UNC-2A, SOC. HD. CAP X 5/8LG | Q4650022220   | STEEL        |
| 25               | 4    | SCREW, 10-32 UNC-2A, PAN HEAD X 5/8LG    | Q2250012620   | STEEL        |
| 24               | 2    | ELBOW, 3/8 NPT X 1/2 I. N. TUBE COMPR.   | P215-125      | BRASS        |
| 23               | 1    | DRIVE UNIT                               | D10-77053     | ALUM         |
| 22               | 1    | SPACER                                   | D21-62050     | AL. ALLOY    |
| 21               | 2    | ELBOW, 1/8 NPTM X 1/4 O. D. TUBE COMPR.  | P215-251      | BRASS        |
| 20               | 1    | SCREW, SET 1/4-28UNF-2A X 1/4LG          | Q380023211    | STEEL        |
| 19               | 1    | COUPLING                                 | B18-62028     | STEEL        |
| 18               | 1    | PILOT VALVE ASSEMBLY                     | C13-63035     | PER DETAILS  |
| 17               | 2    | SCREW, 5/16-18UNC-2A SC. HD. CAP X 2LG   | Q4650023540   | STEEL        |
| 16               | 2    | SPACER, TUBE                             | R26-63035     | STEEL        |
| 15               | 1    | FIL., REG., LUBR. & BRACKET ASSY.        | D24-62050     | PER DETAILS  |
| 14               | 1    | CHECK VALVE, INTAKE                      | B44-11102     | PER DETAILS  |
| 13               | 1    | CHECK VALVE, EXHAUST                     | B44-11107     | PER DETAILS  |
| 12               | 2    | SCREW, #2 TAPPING PAN TYPE B, 1/4LG      | Q2240031111   | STEEL        |
| 11               | 1    | NAME PLATE                               | R52-63070     | ALUM.        |
| 10               | 1    | VALVE, 4-WAY MASTER                      | R223-77020    | PER DETAILS  |
| 9                | 3    | CONNECTOR 3/8 NPT. X 1/2 TUBE, COMPR.    | P215-1041     | BRASS        |
| 8                | 2    | MUFFLER, 3/8 NPT.                        | R40-62028     | AL. & BRONZE |
| 7                | -    | TUBE, 1/2 O. D.                          | P1245-003     | COPPER       |
| 6                | 1    | PILOT VALVE ASSEMBLY                     | C14-63035     | PER DETAILS  |
| 5                | 2    | SPLIT LOCK WASHER 5/16 I. D.             | R1061-053     | STEEL        |
| 4                | 2    | SCREW, 5/16-18UNC-2A SC. HD. CAP 2-3/4LG | Q4650023548   | STEEL        |
| 3                | 6    | SCREW, 5/16-18UNC-2A SC. HD. CAP 1-1/4LG | Q4650023530   | STEEL        |
| 2                | 9    | WASHER, FLAT 5/16 I. D.                  | R12-63167     | STEEL        |
| 1                | 1    | 3/4 DIA. PISTON HEAD ASSEMBLY            | D1-85005      | PER DETAILS  |
|                  |      | DESCRIPTION                              |               |              |
| LIST OF MATERIAL |      |  |               |              |

UNLESS OTHERWISE SPECIFIED  
DIMENSIONS ARE IN INCHES  
TOLERANCES:

FRACTIONS ±  
DECIMALS ± XX ±.002 XXX ±.010  
ANGLES ± 1°

REMOVE ALL BURRS AND SHARP EDGES

DO NOT SCALE THIS DRAWING

| BY       | NAME | DATE | FINISH: |
|----------|------|------|---------|
| PREPARED |      |      |         |
| CHECKED  |      |      |         |
| ENGR/RSK |      |      |         |
| APPROVED |      |      |         |

TITLE AIR OPERATED DIAPHRM  
COMPRESSOR, VERTICAL, SINGLE  
END, 6,000 PSI, 3/4 PISTON

CODE IDENT. NO. 59505  
SIZE D  
PART NO. 46-14065  
DRAWING NO. 4614065A  
SCALE WEIGHT SHEET OF

SEE LIST

PROPRIETARY

This document is issued in strict confidence on condition that it is not copied, reprinted, or disclosed to a third party, except in part, without written consent of Newport Scientific Inc.



NEWPORT SCIENTIFIC INC.  
TITLE AIR OPERATED DIAPHRM  
COMPRESSOR, VERTICAL, SINGLE  
END, 6,000 PSI, 3/4 PISTON  
CODE IDENT. NO. 59505  
SIZE D  
PART NO. 46-14065  
DRAWING NO. 4614065A  
SCALE WEIGHT SHEET OF

NOTE:  
1. MARK OR TAG WITH ASSEMBLY NUMBER

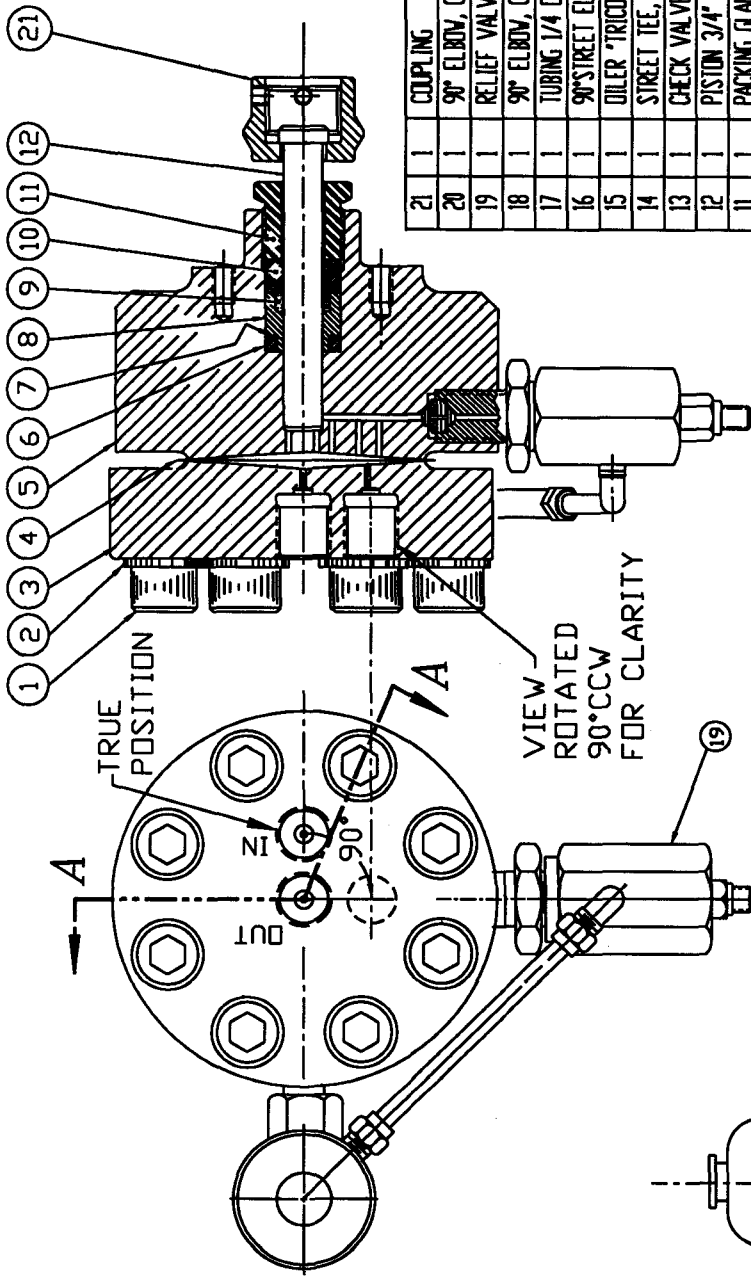

SECTION A-A

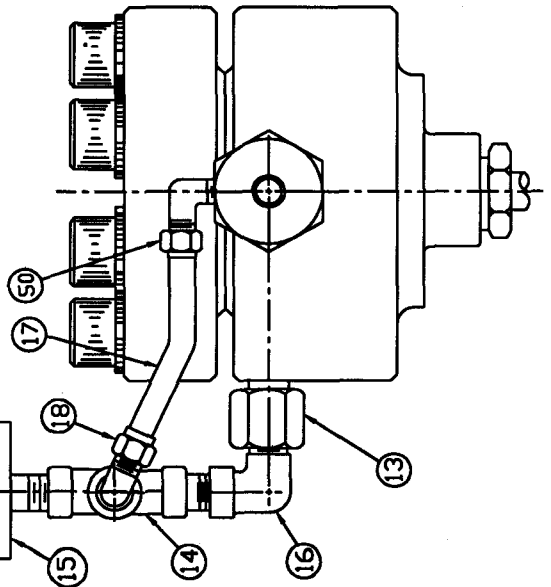

| ITEM No. | No. RECD | DESCRIPTION                                       | PART No.     | MATERIAL         |
|----------|----------|---|--------------|------------------|
| 21       | 1        | COUPLING  | 84001001400  | 17-4 PH          |
| 20       | 1        | 90° ELBOW, COMPRESSION 1/8 NPTM x 1/4 O.D. TUBING | P1245000100  | BRASS            |
| 19       | 1        | RELIEF VALVE - ASSEMBLY                           | 62006001204  | PER DETAILS      |
| 18       | 1        | 90° ELBOW, COMPRESSION 1/4 NPTM x 1/4 O.D. TUBING | P0215025100  | BRASS            |
| 17       | 1        | TUBING 1/4 O.D. 6' LONG (APPROX)                  | P1245000100  | CUPPER           |
| 16       | 1        | 90° STREET ELBOW 1/4 NPT                          | P0201004100  | BRASS            |
| 15       | 1        | OILER "TRICO" TYPE PCH40001                       | P1004002900  | CDMM             |
| 14       | 1        | STREET TEE, 1/4 NPTF x 1/4 NPT MALE RUN           | P0201006100  | BRASS            |
| 13       | 1        | CHECK VALVE, INTAKE (OIL SIDE)                    | 44-14110     | AS PER DETAILS   |
| 12       | 1        | PISTON 3/4" DIAMETER (NOMINAL)                    | 84001000500  | TYPE 40C ST. ST. |
| 11       | 1        | PACKING GLAND NUT                                 | 84001000600  | TYPE 416 ST. ST. |
| 10       | 1        | PACKING FOLLOWER                                  | 84001000700  | AMPCD #15        |
| 9        | 1        | POLYPAK SEAL PACKING                              | P1615009000  | MOLYTHANE        |
| 8        | 1        | PACKING RETAINER                                  | 84001000800  | AMPCD #15        |
| 7        | 1        | BACK-UP RING (8-214-N300-9)                       | P1604110000  | BUNA "N"         |
| 6        | 1        | "O" RING (2-214)                                  | P1604019400  | BUNA "N"         |
| 5        | 1        | BODY  | 84001000900  | ELASTUF-A2       |
| 4        | 1        | DIAPHRAGM   | 84001001100  | TYPE 302 ST. ST. |
| 3        | 1        | HEAD  | 84001001000  | 17-4 PH. ST. ST. |
| 2        | 8        | WASHER, PLAIN 21/32 I.D. x 1/8 THICK              | P1634041400  | STEEL, HARDENED  |
| 1        | 8        | SCREW 5/8-18UNF-2A, SOCKET HEAD CAP x 3" LONG     | P02030074000 | STEEL BL. DK.    |

LIST OF MATERIAL

UNLESS OTHERWISE SPECIFIED  
DIMENSIONS ARE IN INCHES  
TOLERANCES:

FRACTIONS ± .005  
DECIMALS ± .010  
ANGLES ± 0°-30'  
HOLE IN BORE AND BORE SIZE  
DO NOT SCALE THIS DRAWING

PROPERTY  
This drawing is the property of  
the company and is not to be  
reproduced or used in any way  
without the written consent of  
the company.

SCALE: AS SHOWN  
DATE: 11/18/50  
DRAWN: J. H. BROWN  
CHECKED: R. L. BROWN  
APPROVED: J. H. BROWN

HEAD ASSEMBLY - 6,000 PSI  
DIAPHRAGM COMP. WITH 3/4 DIA  
PISTON, SINGLE END AIR OPERATED

SEE SH 2  
NEXT ASSY USED ON  
APPLICATION

46-14065  
USED ON

185005  
185005

185005  
185005

185005  
185005

185005  
185005

185005  
185005

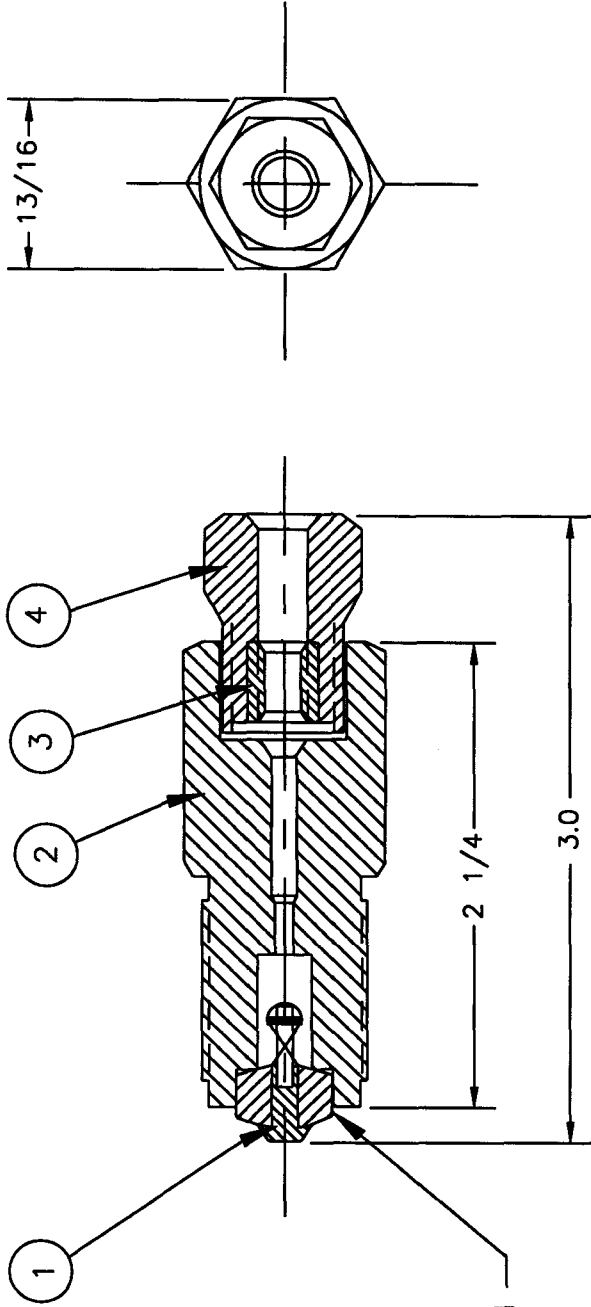

SEE NOTE 1

**NOTES:**

1. STAKE LENS RING OF POPPET; SUB-ASSEMBLY ITEM 1 IN PLACE WITH CENTER PUNCH IF NECESSARY.
2. TIGHTEN GLAND NUT ITEM 4 HAND TIGHT FOR SHIPPING.
3. TIGHTEN GLAND NUT ITEM 4 TO A TORQUE OF 15 FT./LBS. APPROX. WITH TUBING INSTALLED.
4. PRESS. RATING = 10,000 P.S.I.
5. ELECTRO ETCH/MARK

- A. SUPERPRESSURE DIAMOND
- B. CAT NO.
- C. PRESSURE RATING (IF APPLICABLE)
- D. LOT NO. (IF APPLICABLE)
- E. D.O.M.
- F. FLOW ARROW (IF APPLICABLE)

| ITEM | QTY. | DESCRIPTION         | PART NO.    | MATERIAL          |
|------|------|---------------------|-------------|-------------------|
| 1    | 1    | POPET; SUB-ASSEMBLY | 66005000100 | AS PER DETAIL     |
| 2    | 1    | VALVE BODY          | 62004001000 | TYPE 316 ST. STL. |
| 3    | 1    | INNER SLEEVE        | 45-11316    | TYPE 416 ST. STL. |
| 4    | 1    | GLAND NUT           | 45-11313    | TYPE 416 ST. STL. |
| ITEM | QTY. | DESCRIPTION         | PART NO.    | MATERIAL          |

**LIST OF MATERIAL**

APPROVED: \_\_\_\_\_  
 USED ON: \_\_\_\_\_  
 NEXT ASY: \_\_\_\_\_

UNLESS OTHERWISE SPECIFIED  
 DIMENSIONS ARE IN INCHES  
 TOLERANCES:  
 FRACTIONS ±  
 DECIMALS ±  
 ANGLES ±

REMOVE ALL BURRS AND SHARP EDGES  
 DO NOT SCALE THIS DRAWING  
 FINISH:  
 BY: \_\_\_\_\_ DATE: \_\_\_\_\_  
 CHECKED: \_\_\_\_\_  
 DESIGNED: \_\_\_\_\_  
 APPROVED: \_\_\_\_\_  
 MATERIAL: \_\_\_\_\_

SCALE: \_\_\_\_\_  
 SHEET NO. 44-11102  
 DRAWING NO. 4411102

PROPRIETARY  
 This document is issued in strict confidence on condition that it is not copied, reprinted, or disclosed to a third party, wholly or in part, without written consent of Newport Scientific Inc.

SUPERPRESSURE SCIENTIFIC INC.  
 GAS SERVICE  
 CHECK VALVE 10,000 PSI INTAKE  
 SOFT SEAT

SIZE: \_\_\_\_\_ WEIGHT: \_\_\_\_\_  
 PART NO. 44-11102  
 DRAWING NO. 4411102  
 SHEET \_\_\_\_\_ OF \_\_\_\_\_





**ELECTRO ETCH/MARK**

- A. SUPERPRESSURE DIAMOND
- B. CAT NO.
- C. PRESSURE RATING (IF APPLICABLE)
- D. LOT NO. (IF APPLICABLE)
- E. D.O.M.
- F. FLOW ARROW (IF APPLICABLE)

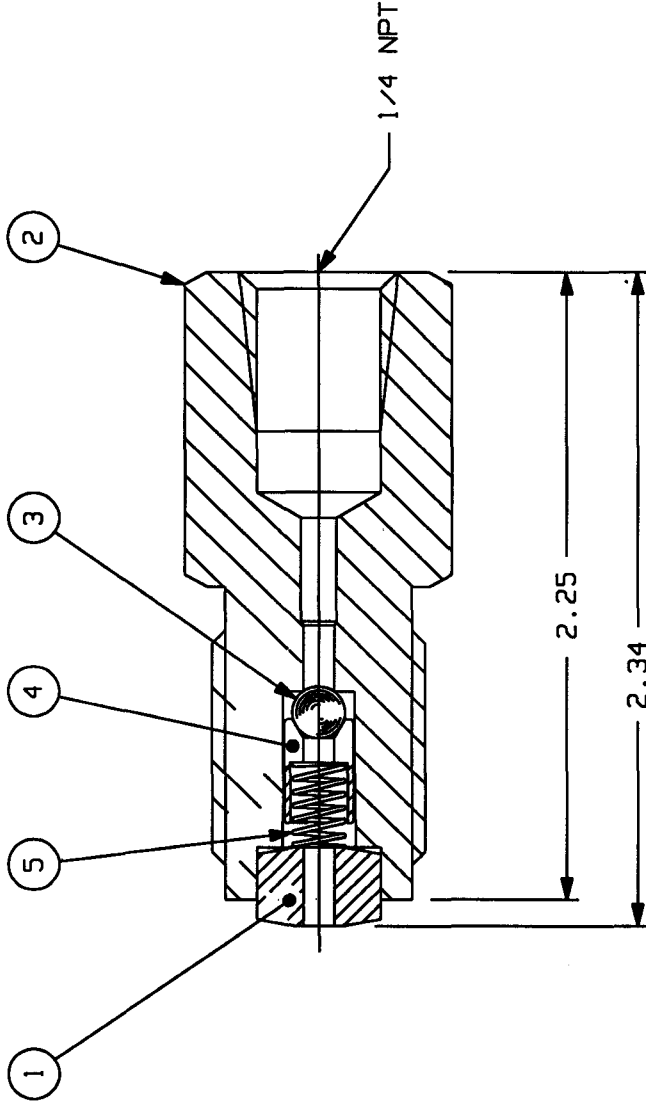
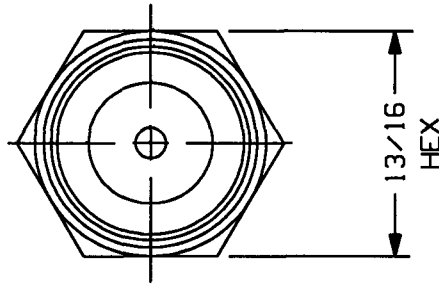

- NOTES:**
1. STRIKE ITEM 1 (LENS RING) IN PLACE WITH A CENTER PUNCH IF NECESSARY.
  2. DIMENSIONS SHOWN ARE FOR REFERENCE ONLY

| ITEM | QTY | DESCRIPTION   | DMG/PART NO. | MATERIAL                    |
|------|-----|---------------|--------------|-----------------------------|
| 5    | 1   | SPRING        | 50029003204  | TYPE 18-8 STAINLESS STEEL   |
| 4    | 1   | BALL RETAINER | 62002000400  | TYPE 316 STAINLESS STEEL    |
| 3    | 1   | BALL          | P1500013300  | TYPE 440 STAINLESS STEEL    |
| 2    | 1   | BODY          | 62079000400  | TYPE 316 STAINLESS STEEL    |
| 1    | 1   | LENS RING     | 63038000400  | TYPE 17-4PH STAINLESS STEEL |

LIST OF MATERIAL

**PROPRIETARY**

This document is issued in strict confidence on a condition that it is not copied, reprinted, or disclosed to a third party, wholly or in part, without written consent of Newport Scientific Inc.

UNLESS OTHERWISE SPECIFIED DIMENSIONS ARE IN INCHES  
TOLERANCES:  
FRACTIONS ± SEE  
DECIMALS ± NOTES  
ANGLES ±  
REMOVE ALL BURRS AND SHARP EDGES  
DO NOT SCALE THIS DRAWING  
MATERIAL:

NEXT ASSY. USED ON APPLICATION

SEE MATERIAL LIST

CONTRACT BY NAME DATE PREPARED CHECKED ENGR/DISGN APPROVED CERTIFICATION



LIQUID SERVICE  
CHECK VALVE 40,000 PSI INTAKE

CODE IDENT. NO. 59505  
SIZE  
PART NO. 44-14110  
DRAWING NO. 4414110  
SCALE WEIGHT SHEET 1 OF 1

REVISIONS

| SYM | DESCRIPTION    | DATE    | APPROVED |
|-----|----------------|---------|----------|
| A   | ADDED ITEM #10 | 10-2-01 |          |

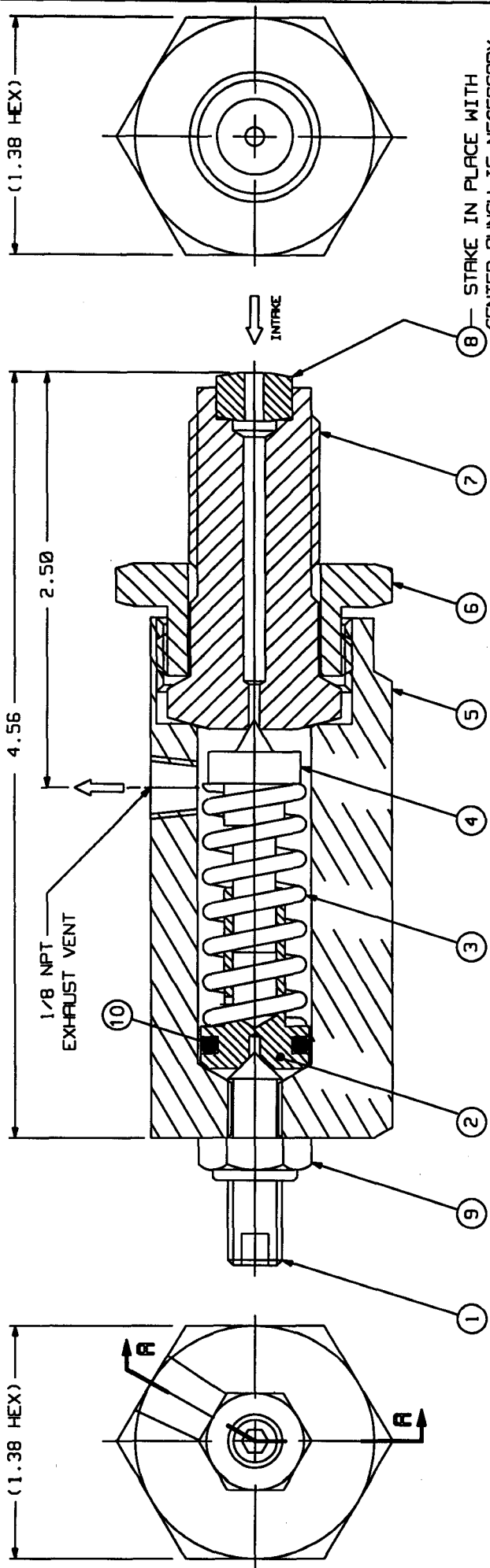

STAMP PART NO. AND D.O.M.

SECTION R-R

| DASH NO. | ORIFICE DIA | PRESSURE RANGE (PSI) |
|----------|-------------|----------------------|
| -4       | .125        | 3,000 - 7,500        |
| -3       | .046        | 20,000 - 50,000      |
| -2       | .062        | 14,000 - 35,000      |
| -1       | .093        | 5,000 - 14,000       |

REPLACES DRAWING NO. B1-62006

| ITEM QTY | DESCRIPTION                             | DWG/PART NO. | MATERIAL             |
|----------|---|--------------|----------------------|
| 10       | 1 O" RING                               | P1604025100  | BUNA "N" STEEL       |
| 9        | 1 STOP NUT, THIN ELASTIC, 5/16-24UNF-2B | P1054005500  | STEEL                |
| 8        | 1 GASKET, LENS RING                     | 63038000400  | 17-4 PH STEEL        |
| 7        | 1 VALVE SEAT (SEE CHART)                | 62006001000  | 17-4 PH STEEL        |
| 6        | 1 NUT                                   | 62006001100  | CRS                  |
| 5        | 1 BODY                                  | 62006000900  | CRS                  |
| 4        | 1 STEM                                  | 64079000200  | 440C STAINLESS STEEL |
| 3        | 1 SPRING                                | P1632014900  | ALLOY STEEL          |
| 2        | 1 GUIDE, SPRING                         | 64079000300  | 416 STAINLESS STEEL  |
| 1        | 1 SET SCREW, SOCKET HD, 5/16-24UNF-2A   | 62006000800  | STEEL                |

LIST OF MATERIAL

UNLESS OTHERWISE SPECIFIED DIMENSIONS ARE IN INCHES TOLERANCES: FRACTIONS ± DECIMALS ± .03 ANGLES ± REMOVE ALL BURRS AND SHARP EDGES DO NOT SCALE THIS DRAWING

BY: NAME DATE FINISH: PREPARED CHECKED ENGR/DROR APPROVED MATERIAL

NEWPORT SCIENTIFIC INC. SUPER-PRESSURE

ASSEMBLY RELIEF VALVE FOR LIQUID SERVICE

CODE DASH. NO. 59505 PART NO. 62006001200 DRAWING NO. 1262006

SCALE 2=1 WEIGHT SHEET 1 OF 1



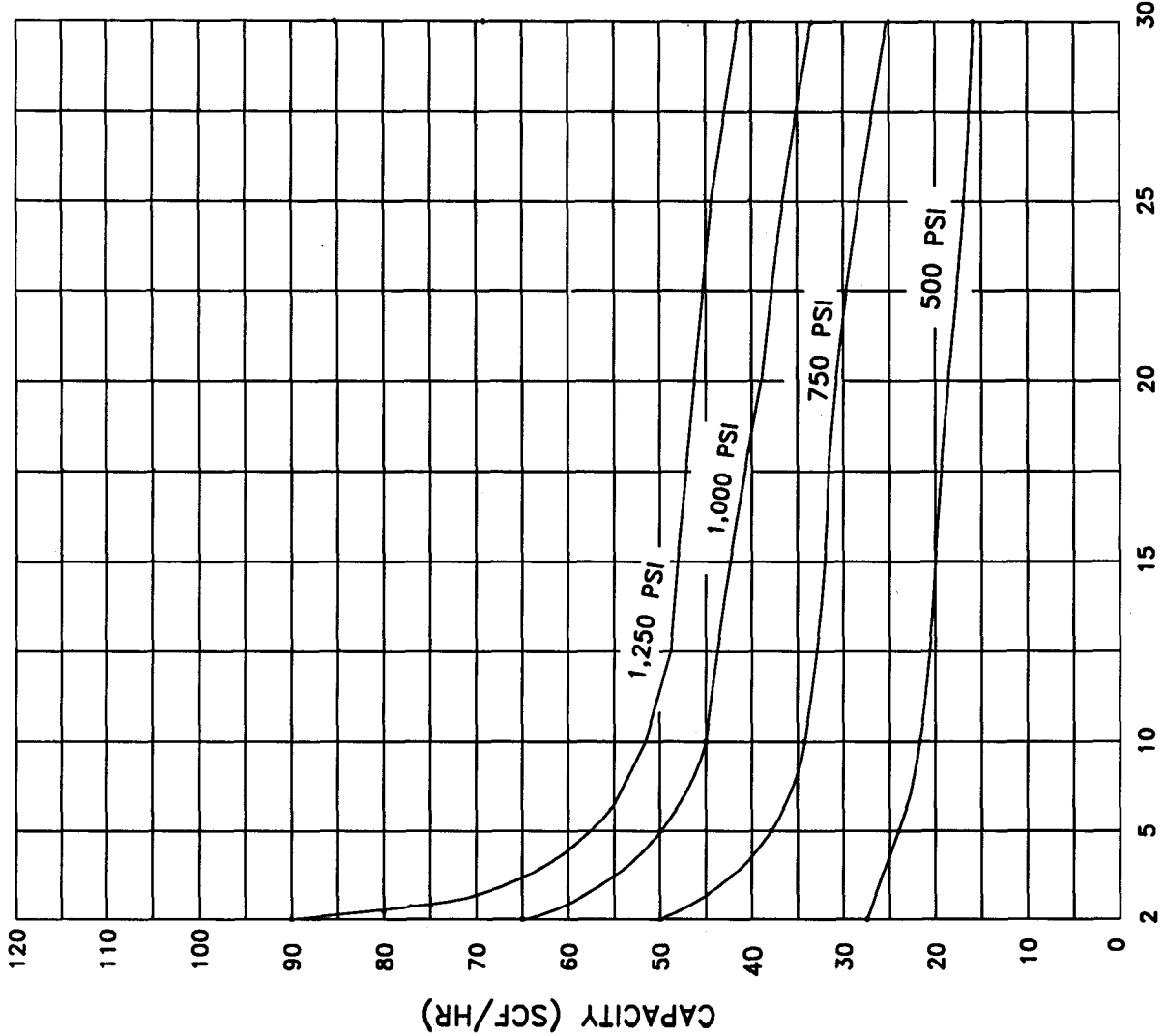

TEST DATA GAS: NITROGEN  
 TEMPERATURE : 70°F  
 OIL : SAE20  
 AIR DRIVE : 90 PSI  
 PRESSURE : NOMINAL

**PROPRIETARY**  
 This document is issued in strict confidence on condition that it is not copied, reprinted, or disclosed to a third party, singly or in part, without written consent of Newport Scientific Inc.

**NEWPORT SCIENTIFIC INC.**  
 SUPER-PRESSURE

UNLESS OTHERWISE SPECIFIED DIMENSIONS ARE IN INCHES  
 TOLERANCES:  
 FRACTIONS ±  
 DECIMALS ±  
 ANGLES ±

REMOVE ALL BURRS AND SHARP EDGES  
 DO NOT SCALE THIS DRAWING

| BY       | NAME | DATE | FINISH: |
|----------|------|------|---------|
| PREPARED |      |      |         |
| CHECKED  |      |      |         |
| ENGR/DSM |      |      |         |
| APPROVED |      |      |         |
| MATERIAL |      |      |         |

CURVE FOR 2 STAGE 6 & 30K PSI AIR OPERATED # 46-14068

| CODE IDENT. NO. | SIZE | WEIGHT | SHEET | OF |
|-----------------|------|--------|-------|----|
| 59505           |      |        |       |    |

DRAWING NO. CURV630AIR

| APPLICATION | USED ON |
|-------------|---------|
| NEXT ASSY   |         |